



AJ Manufacturing Co., Inc.  
 8701 Elmwood Avenue  
 Suite 400  
 Kansas City, MO 64132-1603  
[www.ajmfg.com](http://www.ajmfg.com)

# Commercial Submittal Sheet

## A550H-45-FG Series

### Fixed 45° Airfoil Blade Filter Grille

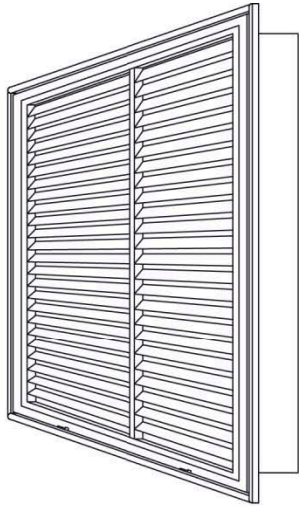

**Model:** A550H-45-FG  
**Description:** Fixed 45° Airfoil Blade Filter Grille

**Standard Features:**

- Fixed 45° aluminum airfoil blades parallel to the longest dimension
- Hinged removable extruded aluminum face frame with signature line marks
- Hinges parallel to longest side
- Hand operated lever for easy filter access
- 4-way reversible door on square sizes
- 2-way reversible door on rectangular sizes
- Concealed mounting holes with mounting screws
- Holds up to a 1" filter (not included) with filter retention tabs (905FG1)
- Rust resistant pre-coat with durable powder finish
- Soft White

**Options:**

- 2" Filter capacity (A550H-FG2)
- 4" Filter capacity (A550H-FG4)
- Blades parallel to shortest dimension (A550V-FG1/A550V-FG2/A550V-FG4)
- Adjustable airfoil blade filter grille (A150H-FG/A150V-FG)
- Fixed 0° aluminum airfoil blades (A550H-0-FG/A550V-0-FG)
- Alternative hinge and latch options – see Filter Grille Order Supplement form on website

**Finishes:**

**Standard Colors**

- Soft White
- Driftwood Tan

**Designer Colors**

- Almond
- Black Velvet
- Bronze
- Camaro Silver

- Coffee Tan
- Navajo White
- Vanilla

**Other**

- Aluminum Paint
- Glossy White
- Mill Finish

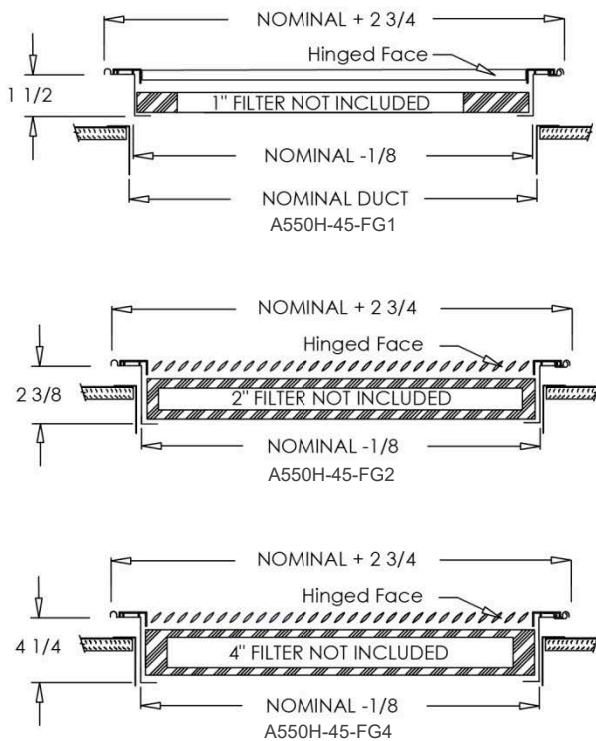

A550-FG1 Frame Detail

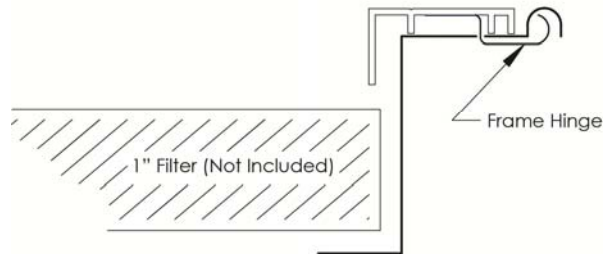

**Product Notes:**

Filter grilles are manufactured 3/16" undersized nominal duct outside dimension for ease of installation. Air filter should be 1/4" to 1/2" undersized. Verify with air filter manufacturer for air specifications.

**Additional Information:**

Project / Location:
Engineer:
Architect:
Contractor:

**Submittal Notes**